



AIRCONCEPTS

AIR DISTRIBUTION PRODUCTS



SDRR-LI SERIES

SDRR-LI

Swirl Diffuser - Round Panel

Swirl Diffuser Dimensions in Inches

MODEL	D	H
SDRR-06-LI	6	4-1/2
SDRR-08-LI	8	4-1/2
SDRR-10-LI	10	4-1/2
SDRR-12-LI	12	5
SDRR-14-LI	14	5

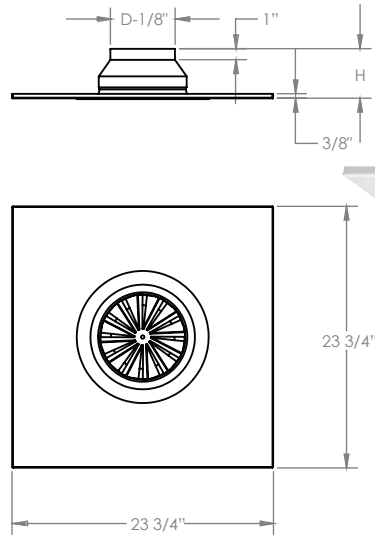

High Velocity/ High Aspiration Air Outlet

- Swirl pattern design
- Lay-in panel
- Easy installation

Construction

- Heavy gauge aluminum face

Finishes

- Standard: #52 White powder coat
- Optional standard: #00 Mill #12 Anodized powder coat
- #42 Gloss black powder coat
- #43 Flat black powder coat finish
- #62 Grey prime powder coat
- #72 Silver metallic powder coat
- Custom colors available

MODEL	Duct Velocity Velocity Pressure	400 0.010	600 0.022	800 0.040	1000 0.062	1200 0.089	1400 0.122
SDRR-06-LI	CFM	78	118	157	196	235	274
	Static Pressure	0.05	0.11	0.19	0.30	0.42	0.58
	NC	<15	<15	23	23	36	41
	Radius of Diffusion	1-2-4	2-3-6	3-4-8	3-5-10	4-6-12	4-7-14
SDRR-08-LI	CFM	140	210	280	350	420	490
	Static Pressure	0.04	0.08	0.14	0.22	0.32	0.43
	NC	<15	17	27	34	39	44
	Radius of Diffusion	2-3-6	3-5-9	4-6-11	5-7-14	6-8-16	7-10-19
SDRR-10-LI	CFM	218	327	436	545	654	763
	Static Pressure	0.03	0.06	0.10	0.16	0.23	0.31
	NC	<15	21	31	38	44	48
	Radius of Diffusion	3-5-9	4-6-11	5-7-13	6-9-18	7-10-20	8-12-24
SDRR-12-LI	CFM	314	471	628	785	942	1099
	Static Pressure	0.03	0.06	0.10	0.16	0.23	0.31
	NC	<15	21	31	38	44	48
	Radius of Diffusion	3-6-10	5-7-12	7-10-18	8-11-23	9-13-26	10-16-29
SDRR-14-LI	CFM	428	641	855	1069	1283	1497
	Static Pressure	0.03	0.06	0.10	0.16	0.23	0.31
	NC	17	22	32	39	45	49
	Radius of Diffusion	4-7-12	6-9-16	8-12-23	10-14-28	11-17-32	12-18-34

Performance data based on ASHRAE 70-06

RADIUS OF DIFFUSION: Horizontal distance (THROW) in feet from the Diffuser at which the maximum velocity has been reduced to specified terminal velocity (Vt).

TERMINAL VELOCITY: Maximum velocity (Vt) in feet per minute at the specified distance from the outlet face (THROW) 150 fpm, 100 fpm and 50 fpm respectively.

AIRFLOW CFM: Standard air density and isothermal conditions.

STATIC PRESSURE: Inches of water gauge required.

NOISE CRITERIA: Noise criteria (NC) curve which is not exceeded with a Room Attenuation of 10db and based on Sound Power Level Re: 10-12 watts.