



AIRCONCEPTS

AIR DISTRIBUTION PRODUCTS



SDL-RF SERIES

SDL-RF

Swirl Diffuser - Round Frame Series

Swirl Diffuser Dimensions in Inches

MODEL	D	C	H
SDL-06-RF	6	1-1/2	3-1/2
SDL-08-RF	8	1-1/2	3-1/2
SDL-10-RF	10	1-1/2	3-1/2
SDL-12-RF	12	1-1/2	3-1/2
SDL-14-RF	14	1-1/2	3-1/2

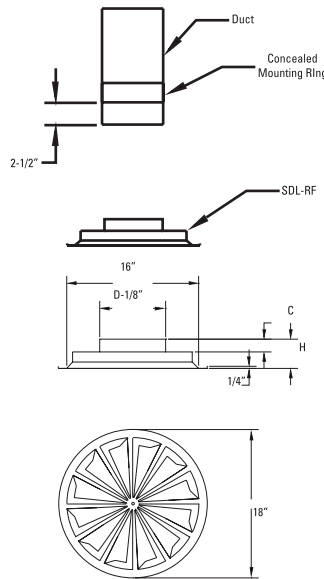

High Velocity/ High Aspiration Air Outlet

Swirl pattern design
Easy installation

Construction

Heavy gauge aluminum face
Aluminum Back Panel
Optional Concealed Mounting System

Finishes

Standard: #52 White powder coat
Optional standard: #00 Mill
#12 Anodized powder coat
#42 Gloss black powder coat
#43 Flat black powder coat finish
#62 Grey prime powder coat
#72 Silver metallic powder coat
Custom colors available

MODEL	Duct Velocity Velocity Pressure	400	600	800	1000	1200	1400
		0.010	0.022	0.040	0.062	0.089	0.122
SDL-06-RF	CFM	78	118	157	196	235	274
	Total Pressure	0.016	0.037	0.065	0.101	0.146	0.2
	NC	<20	<20	<20	22	27	32
	Radius of Diffusion	1-2-4	2-3-5	3-4-6	3-4-7	4-5-8	5-7-9
SDL-08-RF	CFM	140	210	280	350	420	490
	Total Pressure	0.024	0.053	0.065	0.101	0.146	0.2
	NC	<20	<20	21	28	33	38
	Radius of Diffusion	2-3-5	3-4-8	4-5-9	5-7-10	5-8-11	6-9-12
SDL-10-RF	CFM	218	327	436	545	654	763
	Total Pressure	0.029	0.064	0.115	0.192	0.259	0.352
	NC	<20	<20	25	32	37	42
	Radius of Diffusion	2-4-7	3-5-10	4-7-11	6-9-13	7-10-15	2-12-16
SDL-12-RF	CFM	314	471	628	785	942	1099
	Total Pressure	0.037	0.082	0.15	0.222	0.329	0.442
	NC	<20	21	30	37	42	47
	Radius of Diffusion	3-5-10	4-6-12	5-8-15	7-11-16	8-12-17	10-14-19
SDL-14-RF	CFM	428	641	855	1069	1283	1497
	Total Pressure	0.059	0.132	0.23	0.352	0.509	0.692
	NC	<20	26	35	42	48	52
	Radius of Diffusion	3-5-10	4-7-14	6-9-16	8-12-18	9-13-19	11-16-21

Performance data based on ASHRAE 70-06

RADIUS OF DIFFUSION: Horizontal distance (THROW) in feet from the Diffuser at which the maximum velocity has been reduced to specified terminal velocity (Vt).

TERMINAL VELOCITY: Maximum velocity (Vt) in feet per minute at the specified distance from the outlet face (THROW) 150 fpm, 100 fpm and 50 fpm respectively.

AIRFLOW CFM: Standard air density and isothermal conditions.

TOTAL PRESSURE: Inches of water gauge required.

NOISE CRITERIA: Noise criteria (NC) curve which is not exceeded with a Room Attenuation of 10db and based on Sound Power Level Re: 10-12 watts.