

DL-F Series

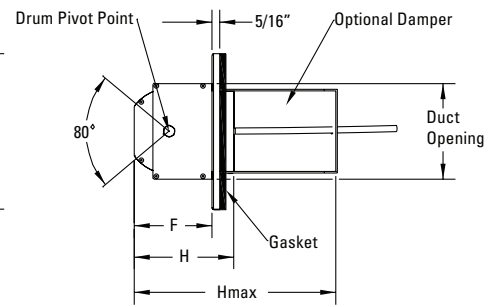
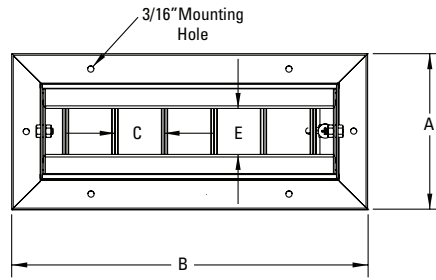
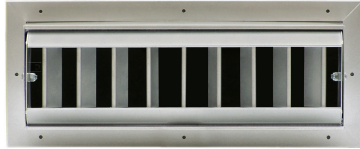

Model	A	B	C	E	F	H	H max	Duct Opening	Min. Duct Dia.	Blade Qty	Mount Holes
DL-1204-F	6-1/2	14-3/8	2	2	3-1/8	4	17-1/4	12 x 4	8	6	6
DL-1804-F		20-3/8						18 x 4		9	8
DL-2404-F		26-3/8						24 x 4		12	10
DL-3004-F		32-3/8						30 x 4		15	10
DL-3604-F		38-3/8						36 x 4		18	12
DL-4204-F		44-3/8						42 x 4		21	12
DL-4804-F		50-3/8						48 x 4		24	14
DL-6004-F		62-3/8						60 x 4		30	16
DL-1206-F	8-1/2	14-3/8	2	3-1/2	3-7/8	4-3/4	18	12 x 6	10	6	6
DL-1806-F		20-3/8						18 x 6		9	8
DL-2406-F		26-3/8						24 x 6		12	10
DL-3006-F		32-3/8						30 x 6		15	10
DL-3606-F		38-3/8						36 x 6		18	12
DL-4206-F		44-3/8						42 x 6		21	12
DL-4806-F		50-3/8						48 x 6		24	14
DL-6006-F		62-3/8						60 x 6		30	16
DL-1208-F	10-1/2	14-3/8	3	5	4-1/2	5-1/2	18-3/4	12 x 8	12	3	6
DL-1808-F		20-3/8						18 x 8		5	8
DL-2408-F		26-3/8						24 x 8		7	10
DL-3008-F		32-3/8						30 x 8		9	10
DL-3608-F		38-3/8						36 x 8		11	12
DL-4208-F		44-3/8						42 x 8		13	12
DL-4808-F		50-3/8						48 x 8		15	14
DL-6008-F		62-3/8						60 x 8		19	16

MATERIAL

- Aluminum
- Foam Gasket

OPTIONS:

- Extractor Damper
- Custom Finish _____

FEATURES

- Low Noise Levels
- Low Pressure Requirements
- Directional Air Pattern Control:
±45 Degree Deflection
±40 Degree Rotation
- 2" Blade Spacing Allows for Increased Spread Control Effectiveness

NOTES:

- Mounting Screws Included

STANDARD FINISH:

- #72 Silver Metallic Powder Coat

Project :	<h2>DL-F Series</h2> <p>Drum Louver - Flat Frame</p> <p>Form # : 40011S</p> <p>Drawn By : MH April 2009</p>
Architect :	
Engineer :	
Contractor :	
Submitted By :	Date :

DL-F Series

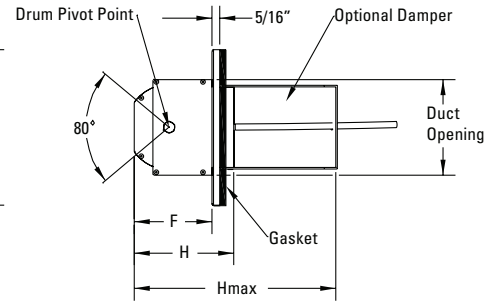
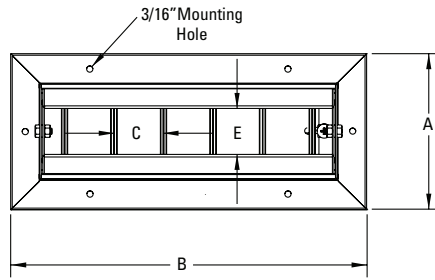
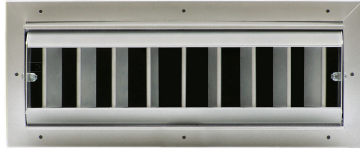

Model	A	B	C	E	F	H	H max	Duct Opening	Min. Duct Dia.	Blade Qty	Mount Holes
DL-1210-F	12-1/2	14-3/8	3	6-5/8	5-1/4	6-1/4	19-1/2	12 x 10	14	3	6
DL-1810-F		20-3/8						5		8	
DL-2410-F		26-3/8						7		10	
DL-3010-F		32-3/8						9		10	
DL-3610-F		38-3/8						11		12	
DL-4210-F		44-3/8						13		12	
DL-4810-F		50-3/8						15		14	
DL-6010-F		62-3/8						19		16	
DL-2012-F	14-1/4	21-7/8	5	8-1/8	7-1/4	8	20-1/4	19-3/4 x 11-3/4	18	3	10
DL-3012-F		31-7/8						5		12	
DL-4012-F		41-7/8						7		14	
DL-5012-F		51-7/8						9		16	
DL-6012-F		61-7/8						11		18	
DL-2015-F	17-1/16	21-7/8	5	10-3/8	8-1/4	9	21-3/4	19-3/4 x 14-3/4	22	3	10
DL-3015-F		31-7/8						5		12	
DL-4015-F		41-7/8						7		14	
DL-5015-F		51-7/8						9		16	
DL-6015-F		61-7/8						11		18	

MATERIAL

- Aluminum
- Foam Gasket

OPTIONS:

- Extractor Damper
- Custom Finish _____

FEATURES

- Low Noise Levels
- Low Pressure Requirements
- Directional Air Pattern Control:
±45 Degree Deflection
±40 Degree Rotation
- 2" Blade Spacing Allows for Increased Spread Control Effectiveness

NOTES:

- Mounting Screws Included

STANDARD FINISH:

- #72 Silver Metallic Powder Coat

Project :	<h2>DL-F Series</h2> <p>Drum Louver - Flat Frame</p> <p>Form # : 40011S</p> <p>Drawn By : MH April 2009</p>
Architect :	
Engineer :	
Contractor :	
Submitted By :	Date :